

DIMENSIONES Y PROPIEDADES PARA DISEÑO

Designación	D	B	d	t	Peso	Area (A)	Eje X - X			Eje Y - Y			x	eo
							I	S	r	I	S	r		
	mm	mm	mm	mm	Kg/m	cm ²	cm ⁴	cm ³	cm	cm ⁴	cm ³	cm	cm	cm
C 6" X 3"	152.4	76.2	25.4	4.5	11.52	14.67	527.4	69.26	3.08	114.9	23.32	2.8	2	
	152.4	76.2	25.4	3	7.91	10.08	372.6	48.89	6.08	83.39	16.96	2.88	2.7	3.2
	152.4	76.2	22.2	2.5	6.53	8.32	312	40.85	6.22	67.7	13.52	2.85	2.	
	152.4	76.2	19.1	2.3	5.92	7.54	284.8	37.88	26.25	52.52	11.68	2.8		
	152.4	76.2	19.1	2	5.18	6.6	250.6	32.88	8.28	52.68	10.34	2.83	2.	
C 6" X 2"	152.4	50.8	22.2	4.5	9.5	12.1	394.4	51.76	5.71	39.49	11.38	1.81	1.61	1.81
	152.4	50.8	19.1	3	6.42	8.17	276.5	36.28	5.92	27.57	7.78	1.84	1.	
	152.4	50.8	19.1	2.5	5.41	6.89	235.9	30.96	5.85	23.92	6.76	1.86	1.54	1.98
	152.4	50.8	15.9	2.3	4.89	6.23	214	28.68	19.66	20.6	5.69	1.82	1.4	
	152.4	50.8	15.9	2	4.28	5.45	188.7	24.76	5.88	18.37	5.07	1.84	1.46	1.98
C 5" X 2"	127	50.8	22.2	4.5	8.6	10.95	253.2	39.88	754.81	373.05	11.04	1.84	1	
	127	50.8	19.1	3	5.82	7.41	179.1	28.2	994.92	25.95	7.63	1.87	1.68	1
	127	50.8	19.1	2.5	4.91	6.26	153.1	24.11	4.93	25.52	6.63	1.9	1.6	
	127	50.8	15.9	2.3	4.43	5.64	139.2	21.92	4.97	19.43	5.58	1.86	1.	
	127	50.8	15.9	2	3.88	4.94	122.9	19.36	051.99	17.33	4.98	1.87	1.6	2
C 4" X 2"	101.6	50.8	22.2	4.5	7.7	9.81	147.4	29.01	3.88	34.04	10.82	1.86	1.93	1.89
	101.6	50.8	19.1	3	5.22	6.65	105.6	20.78	23.93	23.95	7.43	1.9	1.8	
	101.6	50.8	19.1	2.5	4.41	5.62	90.55	17.88	4.06	20.8	6.46	1.92	1	
	101.6	50.8	15.9	2.3	3.97	5.06	82.63	16327	4.04	17.99	5.44	1.89	1.77	2.1
	101.6	50.8	15.9	2	3.48	4.44	73.11	14.79	24.06	16.05	4.85	1.9	1.7	
C 3" X 2"	76.2	50.8	22.2	4.5	6.8	8.67	73.16	19.11	21.95	30.25	10.35	1.87	2.	
	76.2	50.8	19.1	3	4.62	5.89	53.51	14.08	3.04	21.44	7.14	1.91	2.0	
	76.2	50.8	19.1	2.5	3.92	4.99	46.12	12.11	3.02	18.64	6.21	1.93	2	
	76.2	50.8	15.9	2.3	3.51	4.47	42.38	11.92	2.08	16.18	5.23	1.9	1.	
	76.2	50.8	15.9	2	3.08	3.93	37.6	9.87	73.09	14.44	4.67	1.92	1.99	2

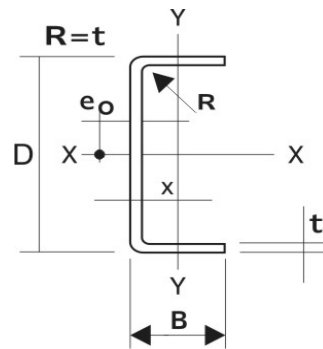

WWW.JAVISAC.COM.PE E-MAIL: MARKETING@JAVISAC.COM.PE

LOCAL TABLADA

LOCAL PROGRESO

LOCAL VILLA MARIA

LOCAL SAN FRANCISCO

LOCAL PUCALLPA

LOCAL LURIN

Av. Pachacutec 5587 Asoc. Unión Colonizadores MZ N Lote 8
 Tablada de Lurín-V.M.T.
 Teléfonos: (01)356-5400
 (01)295-3919
 Celular: 981 436 200
 ventas1@javisac.com.pe

Av. Pachacutec 7789 Nuevo Progreso V.M.T.
 Teléfonos: (01)256-0009
 (01)715-6413
 Celular: 946 395 579
 ventas2@javisac.com.pe

Av. Nicolas de Piérola 721 V.M.T.
 Teléfonos: (01)260-4478
 (01)715-3448
 Celular: 946 395 383
 ventas3@javisac.com.pe

Av. Mz. I Lote 1 Pj. San Francisco Tablada de Lurín-V.M.T.
 Teléfonos: (01)713-0795
 (01)713-0794
 Celular: 970 764 856
 almacen@javisac.com.pe

Av. Centenario Mz. 220 Lote 22 Coronel Portillo Calleria - Ucayali
 Teléfonos: 061-444342
 Celular: 981 436 300
 ventaspucallpa@javisac.com.pe

Predio Rústico Las Salinas de Lurín Sub lote C - 25 -A
 Celular: 981 044 219
 ventas5@javisac.com.pe

DIMENSIONES Y PROPIEDADES PARA DISEÑO

Designación	D mm	B mm	d mm	t mm	Peso Kg/m	Area (A) cm2	Eje X - X			Eje Y - Y			x cm	eo cm
							I cm4	S cm3	r cm	I cm4	S cm3	r cm		
C 9" X 3"	228.6	76.2	25.4	4.5	14.21	18.1	1378	120.5	8.72	131.9	24.45	2.7	2.23	2.84
	228.6	76.2	25.4	3	9.7	12.36	962.8	84.23	8.23	95.55	17.73	2.78	2	
	228.6	76.2	22.2	2.5	8.03	10.22	801.7	70.75	8.86	79.81	14.23	2.		
	228.6	76.2	19.1	2.3	7.3	9.29	729.7	63.80	8.88	67.77	12.21	2.7	2	
	228.6	76.2	19.1	2	6.37	8.12	640.5	56.07	8.87	59.97	10.81	2.72	2.	
C 9" X 2"	228.6	50.8	22.2	4.5	12.19	15.53	1067	93.34	8.29	144.27	11.83	1.		
	228.6	50.8	19.1	3	8.21	10.46	736.8	64.42	8.13	31.03	8.07	1.72	1	
	228.6	50.8	19.1	2.5	6.91	8.8	625.8	54.75	8.43	26.92	7	1.75	1.23	1.77
	228.6	50.8	15.9	2.3	6.26	7.98	566.3	49.54	8.42	23.08	5.89	1.7	1	
	228.6	50.8	15.9	2	5.48	6.98	498.1	43.58	8.45	20.58	5.25	1.72	1.	
C 8" X 3"	203.2	76.2	25.4	4.5	13.31	16.96	1041	102.4	7.83	127	24.14	2.74	2.36	2.91
	203.2	76.2	25.4	3	9.11	11.6	729.4	71.79	7.90	92.03	17.52	2.82	2	
	203.2	76.2	22.2	2.5	7.53	9.59	608.2	59.86	7.96	37.53	13.97	2.7		
	203.2	76.2	19.1	2.3	6.84	8.71	553.9	54.82	7.97	33.39	12.06	2.7		
	203.2	76.2	19.1	2	5.98	7.61	486.5	47.82	7.99	27.86	10.68	2.76	2	
C 8" X 2"	203.2	50.8	22.2	4.5	11.29	14.38	797.6	78.5	7.35	118.22	11.71	1.		
	203.2	50.8	19.1	3	7.61	9.7	552.9	54.42	7.35	30.06	7.99	1.76	1.3	
	203.2	50.8	19.1	2.5	6.41	8.16	470.2	46.28	7.59	26.08	6.93	1.79	1.32	1.84
	203.2	50.8	15.9	2.3	5.8	7.39	425.6	41.82	7.59	22.38	5.84	1.74	1	
	203.2	50.8	15.9	2	5.08	6.47	374.7	36.28	7.62	19.95	5.21	1.76	1.	
C 7" X 3"	177.8	76.2	25.4	4.5	12.41	15.81	758.5	85.32	6.25	12.08	23.77	2		
	177.8	76.2	25.4	3	8.51	10.84	533.5	60.01	7.02	88.01	17.27	2.85	2.52	3.14
	177.8	76.2	22.2	2.5	7.03	8.95	445.7	50.23	7.06	37.536	13.77	2.8		
	177.8	76.2	19.1	2.3	6.38	8.13	406.3	45.7	7.06	62.67	11.89	2.78	2.35	3.12
	177.8	76.2	19.1	2	5.58	7.1	357.1	40.35	7.09	55.45	10.53	2.79	2.	
C 7" X 3/2"	177.8	50.8	22.2	4.5	10.39	13.24	574.6	64.67	6.15	41.73	11.56	1		
	177.8	50.8	19.1	3	7.01	8.94	400.3	45.03	6.69	28.92	7.9	1.8	1.42	1.86
	177.8	50.8	19.1	2.5	5.91	7.53	340.9	38.34	6.73	25.09	6.86	1.83	1.42	1.91
	177.8	50.8	15.9	2.3	5.35	6.81	308.8	34.74	6.73	21.56	5.77	1.78	1.34	1.87
	177.8	50.8	15.9	2	4.68	5.95	272.1	30.6	6.76	19.23	5.15	1.8	1.34	1.9

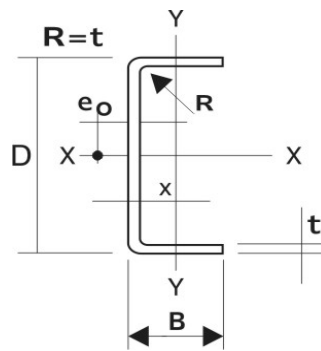

E-MAIL: MARKETING@JAVISAC.COM.PE

WWW.JAVISAC.COM.PE

LOCAL TABLADA

LOCAL PROGRESO

LOCAL VILLA MARIA

LOCAL SAN FRANCISCO

LOCAL PUCALLPA

LOCAL LURIN

Av. Pachacutec 5587 Asoc. Unión Colonizadores MZ Ñ Lote 8
Tablada de Lurín-V.M.T.
Teléfonos: (01)356-5400
(01)295-3919
Celular: 981 436 200
ventas1@javisac.com.pe

Av. Pachacutec 7789
Nuevo Progreso
V.M.T.
Teléfonos: (01)256-0009
(01)715-6413
Celular: 946 395 579
ventas2@javisac.com.pe

Av. Nicolas de Piérola 721
V.M.T.
Teléfonos: (01)260-4478
(01)715-3448
Celular: 946 395 383
ventas3@javisac.com.pe

Av. Mz. I Lote 1 Pj. San Francisco
Tablada de Lurín-V.M.T.
Teléfonos: (01)713-0795
(01)713-0794
Celular: 970 764 856
almacen@javisac.com.pe

Av. Centenario Mz. 220 Lote 22
Coronel Portillo Calleria - Ucayali
Teléfonos: 061-444342
Celular: 981 436 300
ventaspucallpa@javisac.com.pe

Predio Rústico Las Salinas
de Lurín Sub lote C - 25 -A
Celular: 981 044 219
ventas5@javisac.com.pe

DIMENSIONES Y PROPIEDADES PARA DISEÑO

Designación	D mm	B mm	d mm	t mm	Peso Kg/m	Area (A) cm2	Eje X - X			Eje Y - Y			x cm	eo cm
							l	S	r	l	S	r		
							cm4	cm3	cm	cm4	cm3	cm		
C 12" X 3"	304.8	76.2	25.4	4.5	16.9	21.53	2753	1805.6	11.31	24315	25.11	2.		
	304.8	76.2	25.4	3	11.5	14.65	1912	125.5	11.42	103.9	18.19	2.66	1.91	2.77
	304.8	76.2	22.2	2.5	9.52	12.13	1588	104.32	11.84	28591	14.5	2.6		
	304.8	76.2	19.1	2.3	8.67	11.05	1444	94.78	11.78	23691	12.53	2.		
	304.8	76.2	19.1	2	7.57	9.64	1266	83.09	12.42	64.95	11.08	2.6	1.	
C 12" X 2"	304.8	50.8	22.2	4.5	14.88	18.95	2190	143.7	10.75	48	12.09	1.59	1.11	1.45
	304.8	50.8	19.1	3	10.01	12.75	1501	98.48	10.85	33.23	8.23	1.62	1.04	1.53
	304.8	50.8	19.1	2.5	8.4	10.7	1271	83.04	10.59	28.86	7.14	1.64	1.	
	304.8	50.8	15.9	2.3	7.64	9.73	1150	75.47	10.87	24.67	6.01	1.59	0.98	1.53
	304.8	50.8	15.9	2	6.67	8.5	1010	66.28	10.9	22	5.36	1.61	0.97	1.5
C 11" X 3"	279.4	76.2	25.4	4.5	16	20.39	2230	159.6	10.46	140	24.92	2.62	2	2
	279.4	76.2	25.4	3	10.9	13.89	1552	111.1	10.57	101.4	18.06	2.7	2	2.84
	279.4	76.2	22.2	2.5	9.02	11.49	1290	92.37	10.58	21825	14.39	2.		
	279.4	76.2	19.1	2.3	8.21	10.46	1173	83.82	10.55	21774	12.44	2.		
	279.4	76.2	19.1	2	7.17	9.14	1029	73.64	10.61	63.47	11	2.64	1.85	2.8
C 11" X 2"	279.4	50.8	22.2	4.5	13.98	17.81	1759	125.82	9.94	47.53	12.01	1.		
	279.4	50.8	19.1	3	9.41	11.98	1208	86.49	10.59	32.61	8.19	1.65	1	
	279.4	50.8	19.1	2.5	7.9	10.07	1024	73.30	10.09	28.29	7.1	1.68	1	
	279.4	50.8	15.9	2.3	7.18	9.15	926.7	66.34	10.07	24.2	5.98	1.63	1.03	1.59
	279.4	50.8	15.9	2	6.27	7.99	814.2	58.28	10.08	21.58	5.33	1.64	1	
C 10" X 3"	254	76.2	25.4	4.5	15.11	19.24	1773	139.6	9.26	136.2	24.7	2.66	2.	
	254	76.2	25.4	3	10.3	13.12	1236	97.32	9.7	98.66	17.91	2.74	2.11	2.92
	254	76.2	22.2	2.5	8.52	10.86	1028	80.96	9.73	299.77	14.27	2.71	2	
	254	76.2	19.1	2.3	7.75	9.88	935.4	73.65	9.72	859.87	12.33	2.66	1	
	254	76.2	19.1	2	6.77	8.63	820.7	64.62	9.78	61.82	10.91	2.68	1.9	
C 10" X 2"	254	50.8	22.2	4.5	13.08	16.67	1386	109.2	9.12	45.93	11.93	1.66	1.23	1.56
	254	50.8	19.1	3	8.81	11.22	954.4	75.15	9.22	31.87	8.13	1.69	1.1	
	254	50.8	19.1	2.5	7.41	9.43	809.8	63.76	9.26	27.65	7.05	1.71	1.	
	254	50.8	15.9	2.3	6.72	8.56	732.7	57.69	9.25	23.68	5.94	1.66	1.	
	254	50.8	15.9	2	5.88	7.48	644.1	50.72	9.28	21.11	5.29	1.68	1.09	1.68

Longitud Comercial: 6 mts

• Otros largos consultar con su Representante de Ventas

LOCAL TABLADA

Av. Pachacutec 5587 Asoc. Unión Colonizadores MZ Ñ Lote 8
Tablada de Lurín-V.M.T.
Teléfonos: (01)356-5400
(01)295-3919
Celular: 981 436 200
ventas1@javisac.com.pe

LOCAL PROGRESO

Av. Pachacutec 7789
Nuevo Progreso
V.M.T.
Teléfonos: (01)256-0009
(01)715-6413
Celular: 946 395 579
ventas2@javisac.com.pe

LOCAL VILLA MARIA

Av. Nicolas de Piérola 721
V.M.T.
Teléfonos: (01)260-4478
(01)715-3448
Celular: 946 395 383
ventas3@javisac.com.pe

LOCAL SAN FRANCISCO

Av. Mz. I Lote 1 Pj. San Francisco
Tablada de Lurín-V.M.T.
Teléfonos: (01)713-0795
(01)713-0794
Celular: 970 764 856
almacen@javisac.com.pe

LOCAL PUCALLPA

Av. Centenario Mz. 220 Lote 22
Coronel Portillo Calleria - Ucayali
Teléfonos: 061-444342
Celular: 981 436 300
ventaspucallpa@javisac.com.pe

LOCAL LURIN

Predio Rústico Las Salinas
de Lurín Sub lote C - 25 -A
Celular: 981 044 219
ventas5@javisac.com.pe